

TQC9003 Preliminary

Low Power Spread Spectrum Oscillator

TOKYO QUARTZ CO.,LTD

Features

- Frequency range from 1 MHz to 110 MHz
- LVCMOS/LVTTL compatible output
- Standby current as low as 0.4 μ A
- Fast resume time of 3 ms (Typ)
- <30 ps cycle-to-cycle jitter
- Spread options (contact TQC for other spread options)
 - Center spread: $\pm 0.50\%$, $\pm 0.25\%$
 - Down spread: -1% , -0.5%
- Standby, output enable, or spread disable mode
- Industry-standard packages: 2.5 x 2.0, 3.2 x 2.5, 5.0 x 3.2, 7.0 x 5.0 mm x mm
- Thinnest oscillator package: 3.5 x 3.0 x 0.25 mm x mm
- Outstanding mechanical robustness for portable applications
- All-silicon device with outstanding reliability of 2 FIT (10x improvement over quartz-based devices), enhancing system mean-time-to-failure (MTBF)
- Pb-free, RoHS and REACH compliant

Applications

- Printers
- Flat panel drivers
- PCI
- Microprocessors



DC Electrical Characteristics

Parameters	Symbol	Min.	Typ.	Max.	Unit	Condition
Output Frequency Range	f	1	–	110	MHz	
Frequency Tolerance	F_tol	-50	–	+50	ppm	Inclusive of: Initial stability, operating temperature, rated power, supply voltage change, load change, shock and vibration Spread Off
		-100	–	+100	ppm	
Aging	Ag	-1	–	1	ppm	1st year at 25°C
Operating Temperature Range	T_use	-20	–	+70	°C	Extended Commercial
		-40	–	+85	°C	Industrial
Supply Voltage	Vdd	1.71	1.8	1.89	V	
		2.25	2.5	2.75	V	
		2.52	2.8	3.08	V	
		2.97	3.3	3.63	V	
Current Consumption	Idd	–	3.7	4.1	mA	No load condition, f = 20 MHz, Vdd = 2.5 V, 2.8 V or 3.3 V
		–	3.2	3.5	mA	No load condition, f = 20 MHz, Vdd = 1.8 V
Standby Current	I_std	–	2.4	4.3	μ A	\overline{ST} = GND, Vdd = 3.3 V, Output is Weakly Pulled Down
		–	1.2	2.2	μ A	\overline{ST} = GND, Vdd = 2.5 or 2.8 V, Output is Weakly Pulled Down
		–	0.4	0.8	μ A	\overline{ST} = GND, Vdd = 1.8 V, Output is Weakly Pulled Down
Duty Cycle	DC	45	–	55	%	All Vdds. f \leq 70 MHz
		40	–	60	%	All Vdds. f >70 MHz
Rise/Fall Time	Tr, Tf	–	1	2	ns	20% - 80% Vdd=2.5 V, 2.8 V or 3.3 V, 15 pf load
		–	1.3	2.5	ns	20% - 80% Vdd=1.8 V, 15 pf load
Output Voltage High	VOH	90%	–	–	Vdd	IOH = -4 mA (Vdd = 3.3 V)
						IOH = -3 mA (Vdd = 2.8 V and 2.5 V)
						IOH = -2 mA (Vdd = 1.8 V)
Output Voltage Low	VOL	–	–	10	%Vdd	IOL = -4 mA (Vdd = 3.3 V)
						IOL = -3 mA (Vdd = 2.8 V and 2.5 V)
						IOL = -2 mA (Vdd = 1.8 V)
Output Load	Ld	–	–	15	pF	At maximum frequency and supply voltage. Contact TQCime for higher output load option
Input Voltage High	VIH	70%	–	–	Vdd	Pin 1, OE or \overline{ST} or SD
Input Voltage Low	VIL	–	–	30%	Vdd	Pin 1, OE or \overline{ST} or SD
Startup Time	T_start	–	–	10	ms	Measured from the time Vdd reaches TQCs rated minimum value
Resume Time	T_resume	–	3.0	3.8	ms	Measured from the time ST pin crosses 50% threshold
Cycle-to-Cycle Jitter	T_cyc	–	–	26	ps	f = 50 MHz, Spread = ON
		–	–	26	ps	f = 50 MHz, Spread = OFF

TQC9003

Low Power Spread Spectrum Oscillator

TOKYO QUARTZ CO.,LTD

Spread Spectrum Modes^[1]

Code	Center Spread		Down Spread	
	B	D	O	Q
Percentage	±0.25%	±0.50% ^[2]	-0.5%	-1.0% ^[2]

Notes:

1. In both center spread and down spread modes, triangle modulation is employed with a frequency of ~32 kHz.
2. ±0.5% and -1.0% are available ONLY for <75 MHz in extended commercial temperature range.

Pin Configuration

Pin	Symbol		Functionality
1	ST/OE/SD	Standby (ST)	H or Open ^[3] : specified frequency output L: output is low (weak pull down). Oscillator stops
		Output Enable (OE)	H or Open ^[3] : specified frequency output L: output is high impedance.
		Spread Disable (SD)	H or Open: Spread = ON L: Spread = OFF
2	GND	Ground	Connect to Ground
3	CLK	Output	Clock Output
4	VDD	Power Supply	

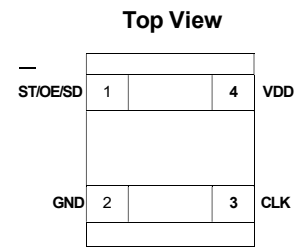

Note:

3. In 1.8 V mode, a resistor of <10 kΩ between OE pin and VDD is recommended.

Absolute Maximum

Attempted operation outside the absolute maximum ratings of the part may cause permanent damage to the part. Actual performance of the IC is only guaranteed within the operational specifications, not at absolute maximum ratings.

Parameters	Min.	Max.	Unit
Storage Temperature	-65	150	°C
VDD	-0.5	4	V
Electrostatic Discharge	-	2000	V
Soldering Temperature (follow standard Pb free soldering guidelines)	-	260	°C
Number of Program Writes	-	1	NA
Program Retention over -40 to 125C, Process, VDD (0 to 3.65V)	-	1,000+	years

Thermal Considerations

Package	Lead Count	Center Pad	Junction-to-Ambient Thermal Resistance (°C/W)		Junction-to-Case ^[6] (bottom) Thermal Resistance (°C/W)
			4 Layer Board ^[5]	2 Layer Board ^[4]	
7050	4	Soldered down	43.6	229	2.6
7050	4	Not soldered down	191	263	2.6
7050	4	No center pad	142	273	29.8
5032	4	No center pad	96.8	199	24
3225	4	No center pad	109	212	27
2520	4	No center pad	117	222	26

Notes:

4. Test boards compliant with JESD51-3.
5. Test boards compliant with JESD51-7.
6. Referenced to bottom of case.

TQC9003

Low Power Spread Spectrum Oscillator

Environmental Compliance

Parameter	Condition/Test Method
Mechanical Shock	MIL-STD-883F, Method2002
Mechanical Vibration	MIL-STD-883F, Method2007
Temperature Cycle	JESD22, Method A104
Solderability	MIL-STD-883F, Method2003
Moisture Sensibility Level	MSL1

Startup and Resume Timing Diagram

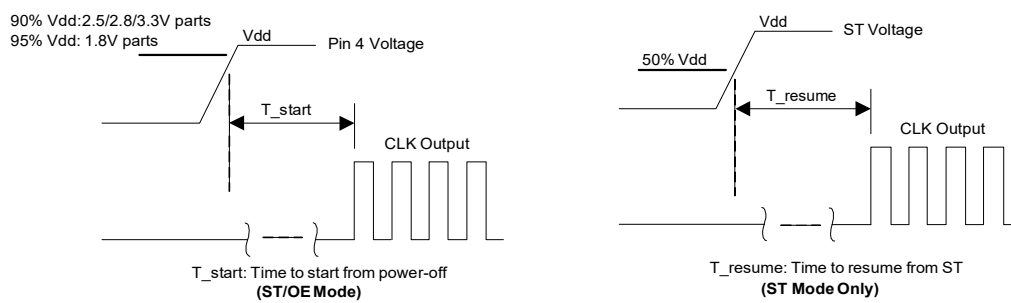

TQC9003

Low Power Spread Spectrum Oscillator

TOKYO QUARTZ CO.,LTD

Programmable Drive Strength

The TQC9003 includes a programmable drive strength feature to provide a simple, flexible tool to optimize the clock rise/fall time for specific applications. Benefits from the programmable drive strength feature are:

- Improves system radiated electromagnetic interference (EMI) by slowing down the clock rise/fall time
- Improves the downstream clock receiver's (RX) jitter by decreasing (speeding up) the clock rise/fall time.
- Ability to drive large capacitive loads while maintaining full swing with sharp edge rates.

For more detailed information about rise/fall time control and drive strength selection, see the TQC Application Notes section;

EMI Reduction by Slowing Rise/Fall Time

Figure 1 shows the harmonic power reduction as the rise/fall times are increased (slowed down). The rise/fall times are expressed as a ratio of the clock period. For the ratio of 0.05, the signal is very close to a square wave. For the ratio of 0.45, the rise/fall times are very close to near-triangular waveform. These results, for example, show that the 11th clock harmonic can be reduced by 35 dB if the rise/fall edge is increased from 5% of the period to 45% of the period.

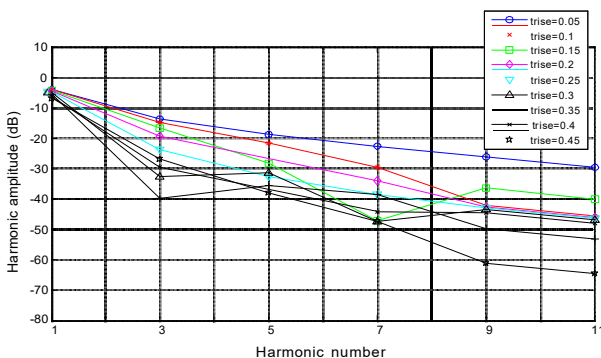

Figure 1. Harmonic EMI reduction as a Function of Slower Rise/Fall Time

Jitter Reduction with Faster Rise/Fall Time

Power supply noise can be a source of jitter for the downstream chipset. One way to reduce this jitter is to increase rise/fall time (edge rate) of the input clock. Some chipsets would require faster rise/fall time in order to reduce their sensitivity to this type of jitter. The TQC9003 provides up to 3 additional high drive strength settings for very fast rise/fall time. Refer to the [Rise/Fall Time Tables](#) to determine the proper drive strength.

High Output Load Capability

The rise/fall time of the input clock varies as a function of the actual capacitive load the clock drives. At any given drive strength, the rise/fall time becomes slower as the output load

increases. As an example, for a 3.3V TQC9003 device with default drive strength setting, the typical rise/fall time is 1.1ns for 15 pF output load. The typical rise/fall time slows down to 2.9ns when the output load increases to 45 pF. One can choose to speed up the rise/fall time to 1.9ns by then increasing the drive strength setting on the TQC9003.

The TQC9003 can support up to 60 pF or higher in maximum capacitive loads with up to 3 additional drive strength settings. Refer to the [Rise/Fall Time Tables](#) to determine the proper drive strength for the desired combination of output load vs. rise/fall time

TQC9003 Drive Strength Selection

Tables 1 through 4 define the rise/fall time for a given capacitive load and supply voltage.

1. Select the table that matches the TQC9003 nominal supply voltage (1.8V, 2.5V, 2.8V, 3.3V).
2. Select the capacitive load column that matches the application requirement (15 pF to 60 pF)
3. Under the capacitive load column, select the desired rise/fall times.
4. The left-most column represents the part number code for the corresponding drive strength.
5. Add the drive strength code to the part number for ordering purposes.

Calculating Maximum Frequency

Based on the rise and fall time data given in Tables 1 through 4, the maximum frequency the oscillator can operate with guaranteed full swing of the output voltage over temperature as follows:

$$\text{Max Frequency} = \frac{1}{5 \times \text{Trf}_{20/80}}$$

Where $\text{Trf}_{20/80}$ is the typical rise/fall time at 20% to 80% Vdd

Example 1

Calculate f_{MAX} for the following condition:

- Vdd = 3.3V (Table 1)
- Capacitive Load: 30 pF
- Desired Tr/f time = 1.6ns (rise/fall time part number code = Z)

Part number for the above example:

TQC9003AIZ14-33EB-105.12345



Drive strength code is inserted here. Default setting is “-”

TQC9003

Low Power Spread Spectrum Oscillator

TOKYO QUARTZ CO.,LTD

Rise and Fall Time Tables

Table 1. Rise/Fall Times, VDD = 3.3V ±10%, T = 40°C to 85°C

Drive Strength		Unit	Load (pF)			
			15	30	45	60
U	Max.	ns	2.4	3.5	5.5	6.4
	Typ.	ns	1.7	2.8	4.3	5.4
x or "-": Default	Max.	ns	2.0	2.5	3.9	4.8
	Typ.	ns	1.1	2.0	2.9	3.8
Z	Max.	ns	1.2	2.0	3.0	3.7
	Typ.	ns	0.8	1.6	2.2	2.9
H	Max.	ns	0.9	1.7	2.5	3.0
	Typ.	ns	0.6	1.3	1.9	2.3

Table 3. Rise/Fall Times, VDD = 2.5V ±10%, T = 40°C to 85°C

Drive Strength		Unit	Load (pF)			
			15	30	45	60
U	Max.	ns	2.8	4.6	6.8	8.3
	Typ.	ns	2.1	3.6	5.2	6.4
X	Max.	ns	2.3	3.3	5.0	5.9
	Typ.	ns	1.4	2.5	3.7	4.7
x or "-": Default	Max.	ns	2.0	2.6	3.4	4.8
	Typ.	ns	1.1	1.9	2.8	3.6
H	Max.	ns	1.3	2.2	3.3	4.0
	Typ.	ns	0.9	1.6	2.3	2.9

Table 2. Rise/Fall Times, VDD = 2.8V ±10%, T = 40°C to 85°C

Drive Strength		Unit	Load (pF)			
			15	30	45	60
U	Max.	ns	2.5	4.1	6.0	7.3
	Typ.	ns	2.0	3.2	4.8	5.9
X	Max.	ns	2.2	3.0	4.5	5.4
	Typ.	ns	1.3	2.2	3.3	4.3
x or "-": Default	Max.	ns	2.0	2.4	3.5	4.3
	Typ.	ns	1.0	1.7	2.5	3.2
H	Max.	ns	1.2	1.9	2.9	3.6
	Typ.	ns	0.7	1.5	2.0	2.6

Table 4. Rise/Fall Times, VDD = 1.8V ±5%, T = 40°C to 85°C

Drive Strength		Unit	Load (pF)			
			15	30	45	60
U	Max.	ns	4.2	6.8	9.4	12.1
	Typ.	ns	3.1	5.1	7.3	9.2
X	Max.	ns	3.2	4.9	6.9	8.7
	Typ.	ns	2.3	3.7	5.3	6.5
Z	Max.	ns	2.7	3.9	5.5	6.7
	Typ.	ns	1.7	2.9	4.2	5.2
x or "-": Default	Max.	ns	2.5	3.3	4.6	5.7
	Typ.	ns	1.4	2.4	3.4	4.3

Note:

7. All rise/fall times are measured for the thresholds of 20% to 80% of VDD.

TQC9003

Low Power Spread Spectrum Oscillator

TOKYO QUARTZ CO.,LTD

Dimensions and Patterns

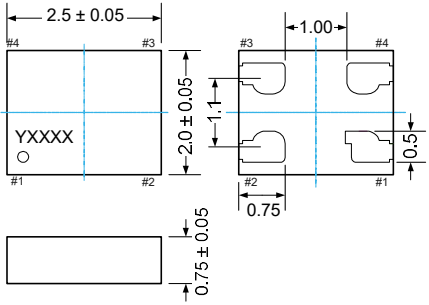
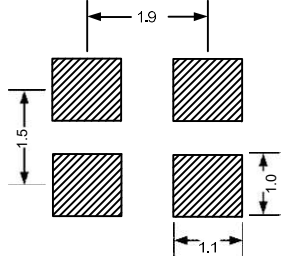
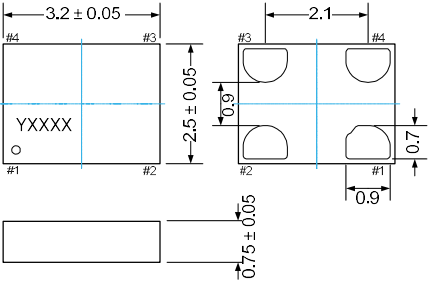
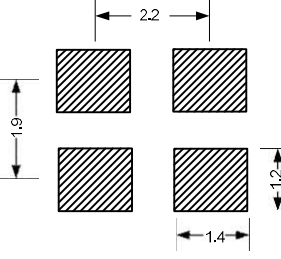
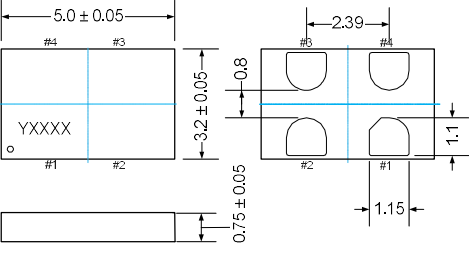
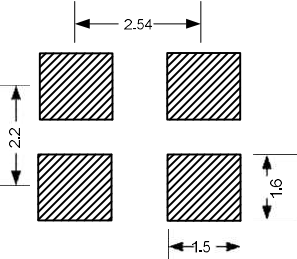
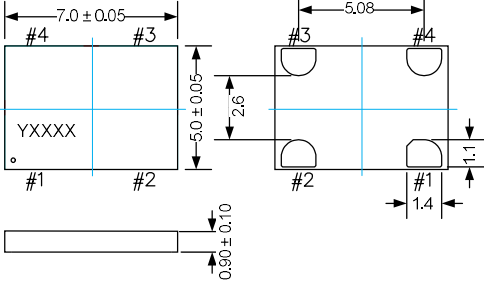
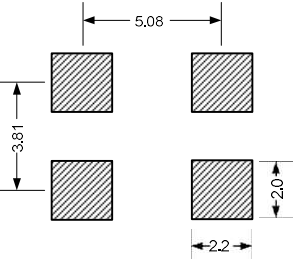
Package Size – Dimensios (Unit: mm) ^[9]	Recommended Land Pattern (Unit: mm) ^[9]
<p>2.5 x 2.0 x 0.75 mm</p> 	
<p>3.2 x 2.5 x 0.75 mm</p> 	
<p>5.0 x 3.2 x 0.75 mm</p> 	
<p>7.0 x 5.0 x 0.90 mm (without center-pad)</p> 	

TQC9003

Low Power Spread Spectrum Oscillator

TOKYO QUARTZ CO.,LTD

Dimensions and Patterns

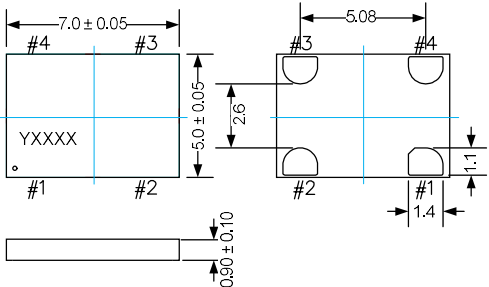
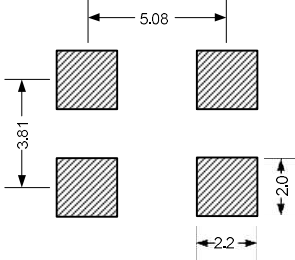
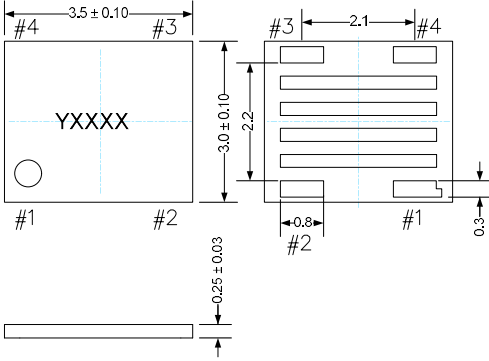
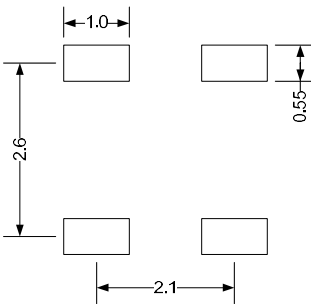
Package Size – Dimensios (Unit: mm) ^[8]	Recommended Land Pattern (Unit: mm) ^[9]
<p>7.0 x 5.0 x 0.90 mm (with Center-Pad)</p> 	
<p>3.5 x 3.0 x 0.25 mm</p> 	

Notes:

- 8. Top marking: Y denotes manufacturing origin and XXXX denotes manufacturing lot number. The value of "Y" will depend on the assembly location of the device.
- 9. A capacitor of value 0.1 μ F between Vdd and GND is required.

TQC9003

Low Power Spread Spectrum Oscillator

TOKYO QUARTZ CO.,LTD

Ordering Information

The Part No. Guide is for reference only. To customize and build an exact part number, use the TQC [Part Number Generator](#).

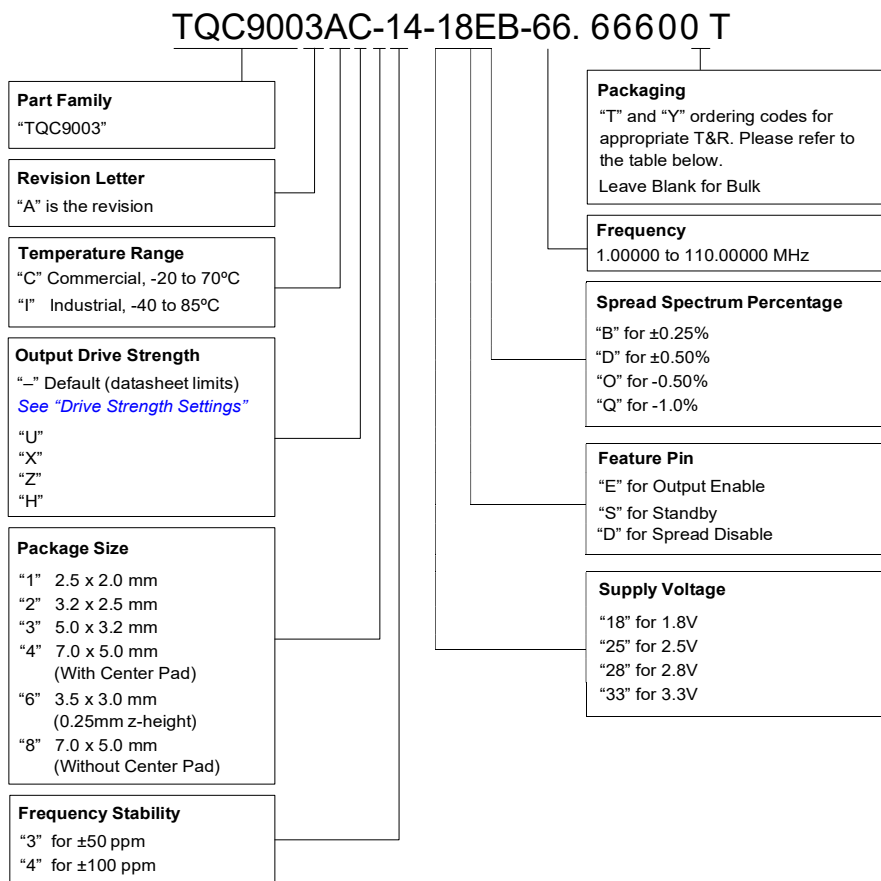

Available Spread Options vs. Temperature and Frequency

Spread Percentage	Temperature Range	
	C = -20 to 70°C	I = -40 to 85°C
B = ±0.25%	1-110 MHz	
D = ±0.50%	1-75 MHz	–
O = -0.50%	1-110 MHz	
Q = -1.0%	1-75 MHz	–

Ordering Codes for Supported Tape & Reel Packing Method

Device Size	12 mm T&R (3ku)	12 mm T&R (1ku)	16 mm T&R (3ku)	16 mm T&R (1ku)
2.5 x 2.0 mm	T	Y	–	–
3.2 x 2.5 mm	T	Y	–	–
5.0 x 3.2 mm	T	Y	–	–
7.0 x 5.0 mm	–	–	T	Y

TQC9003

Low Power Spread Spectrum Oscillator

TOKYO QUARTZ CO.,LTD

Revision History

Version	Release Date	Change Summary
1.62	8/20/13	Added drive strength settings
1.7	11/18/13	Revised rise and fall time tables, added 7050 package diagram with center pad, add thermal considerations.
1.71	4/25/14	Added preliminary information for 0.25 mm thin package.

TQC9003

Low Power Spread Spectrum Oscillator

Silicon MEMS Outperforms Quartz

Best Reliability

Silicon is inherently more reliable than quartz. Figure 1 shows a comparison with quartz technology.

Why is EpiSeal™ MEMS Best in Class:

- EpiSeal MEMS resonators are hermetically vacuum-sealed during wafer processing, which eliminates foreign particles and improves long term aging and reliability
- MEMS resonator is paired with advanced analog IC

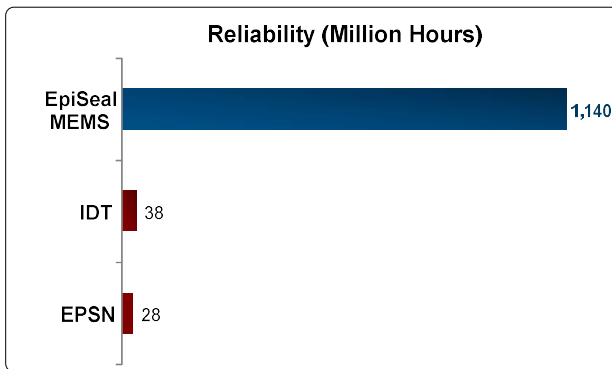

Figure 1. Reliability Comparison^[1]

Best Electro Magnetic Susceptibility (EMS)

EpiSeal MEMS oscillators in plastic packages are up to 54 times more immune to external electromagnetic fields than quartz oscillators as shown in Figure 3.

Why is EpiSeal MEMS Best in Class:

- Internal differential architecture for best common mode noise rejection
- Electrostatically driven MEMS resonator is more immune to EMS

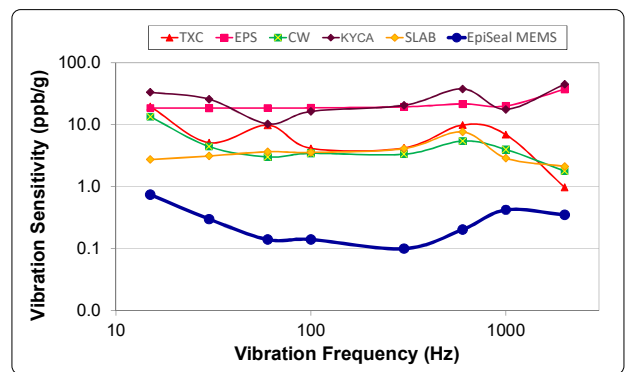

Figure 3. Electro Magnetic Susceptibility (EMS)^[3]

Best Aging

Unlike quartz, EpiSeal MEMS oscillators have excellent long-term aging performance which is why every new EpiSeal MEMS product specifies 10-year aging.

Why is EpiSeal MEMS Best in Class:

- EpiSeal MEMS resonators are hermetically vacuum-sealed during wafer processing, which eliminates foreign particles and improves long term aging and reliability
- Inherently better immunity of electrostatically driven MEMS resonator

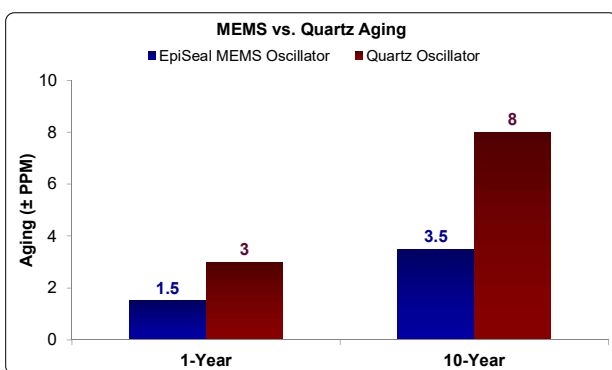

Figure 2. Aging Comparison^[2]

Best Power Supply Noise Rejection

EpiSeal MEMS oscillators are more resilient against noise on the power supply. A comparison is shown in Figure 4.

Why is EpiSeal MEMS Best in Class:

- On-chip regulators and internal differential architecture for common mode noise rejection
- MEMS resonator is paired with advanced analog CMOS IC

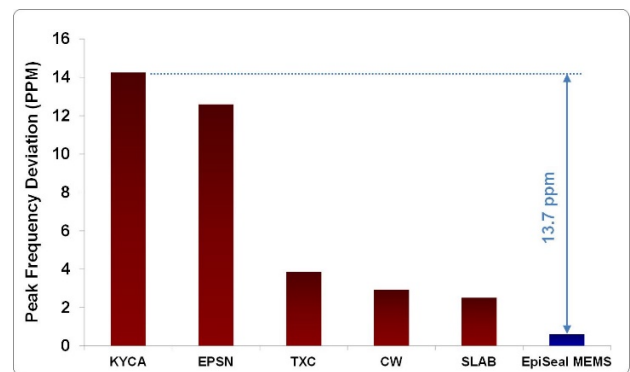

Figure 4. Power Supply Noise Rejection^[4]

TQC9003

Low Power Spread Spectrum Oscillator

Best Vibration Robustness

High-vibration environments are all around us. All electronics, from handheld devices to enterprise servers and storage systems are subject to vibration. Figure 5 shows a comparison of vibration robustness.

Why is EpiSeal MEMS Best in Class:

- The moving mass of MEMS resonators is up to 3000 times smaller than quartz
- Center-anchored MEMS resonator is the most robust design

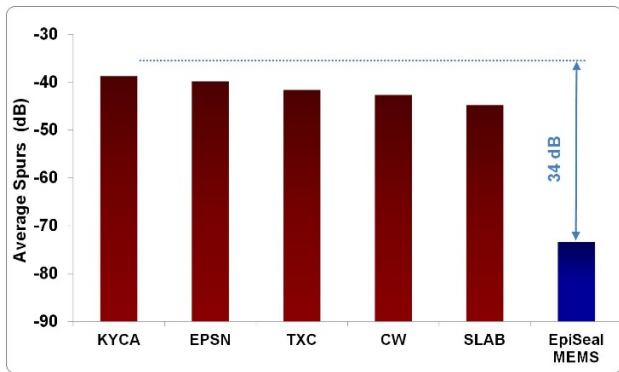

Figure 5. Vibration Robustness^[5]

Best Shock Robustness

EpiSeal MEMS oscillators can withstand at least 50,000g shock. They maintain their electrical performance in operation during shock events. A comparison with quartz devices is shown in Figure 6.

Why is EpiSeal MEMS Best in Class:

- The moving mass of MEMS resonators is up to 3000 times smaller than quartz
- Center-anchored MEMS resonator is the most robust design

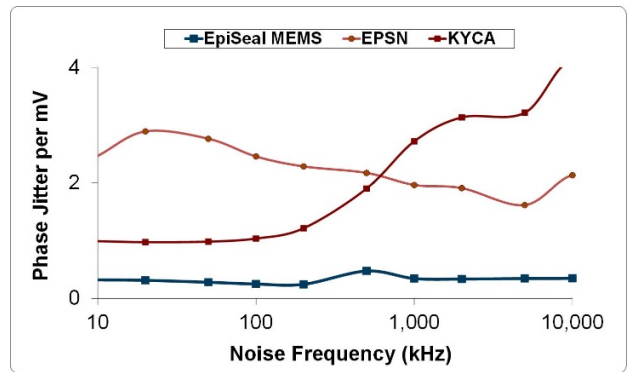

Figure 6. Shock Robustness^[6]

Figure labels:

- TXC = TXC
- Epson = EPSN
- Connor Winfield = CW
- Kyocera = KYCA
- SiLabs = SLAB
- TQC = EpiSeal MEMS

TQC9003

Low Power Spread Spectrum Oscillator

TOKYO QUARTZ CO.,LTD

Notes:

1. Data source: Reliability documents of named companies.
2. Data source: TQC and quartz oscillator devices datasheets.
3. Test conditions for Electro Magnetic Susceptibility (EMS):
 - According to IEC EN61000-4.3 (Electromagnetic compatibility standard)
 - Field strength: 3V/m
 - Radiated signal modulation: AM 1 kHz at 80% depth
 - Carrier frequency scan: 80 MHz – 1 GHz in 1% steps
 - Antenna polarization: Vertical
 - DUT position: Center aligned to antenna

Devices used in this test:

Label	Manufacturer	Part Number	Technology
EpiSeal MEMS	TQC	TQC9120AC-1D2-33E156.250000	MEMS + PLL
EPSN	Epson	EG-2102CA156.2500M-PHPAL3	Quartz, SAW
TXC	TXC	BB-156.250MBE-T	Quartz, 3 rd Overtone
CW	Conner Winfield	P123-156.25M	Quartz, 3 rd Overtone
KYCA	AVX Kyocera	KC7050T156.250P30E00	Quartz, SAW
SLAB	SiLab	590AB-BDG	Quartz, 3 rd Overtone + PLL

4. 50 mV pk-pk Sinusoidal voltage.

Devices used in this test:

Label	Manufacturer	Part Number	Technology
EpiSeal MEMS	TQC	TQC8208AI-33-33E-25.000000	MEMS + PLL
NDK	NDK	NZ2523SB-25.6M	Quartz
KYCA	AVX Kyocera	KC2016B25M0C1GE00	Quartz
EPSN	Epson	SG-310SCF-25M0-MB3	Quartz

5. Devices used in this test:

same as EMS test stated in Note 3.

6. Test conditions for shock test:

- MIL-STD-883F Method 2002
- Condition A: half sine wave shock pulse, 500-g, 1ms
- Continuous frequency measurement in 100 μ s gate time for 10 seconds

Devices used in this test:

same as EMS test stated in Note 3.

7. Additional data, including setup and detailed results, is available upon request to qualified customer.